

BAROSSA CERAMICS

TERRACOTTA COLLECTION



CHABLIS



CHARDONNAY

Barossa Ceramics has been manufacturing high quality terracotta since 1880. High density and low porosity provide excellent stain, abrasion, and salt water resistance. Suitable for interiors, exteriors, commercial locations, driveways and swimming pools. Available in 300x300x15mm

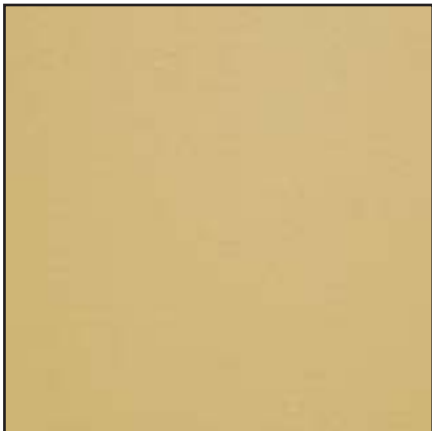

CHAMPAGNE

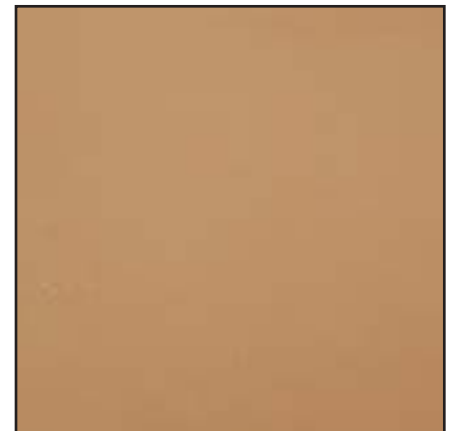

SIENNA



CABERNET



MALBEC

Barossa Ceramics Pty Ltd PO Box 807 Nunawading Delivery Centre Vic 3110
Tel: 1300 856222 Fax: 1300 856214 Email: sales@barossaceramics.com.au
Colours are indicative only, for latest sample please ask your local stockist.

SCULPTURED LEDGE

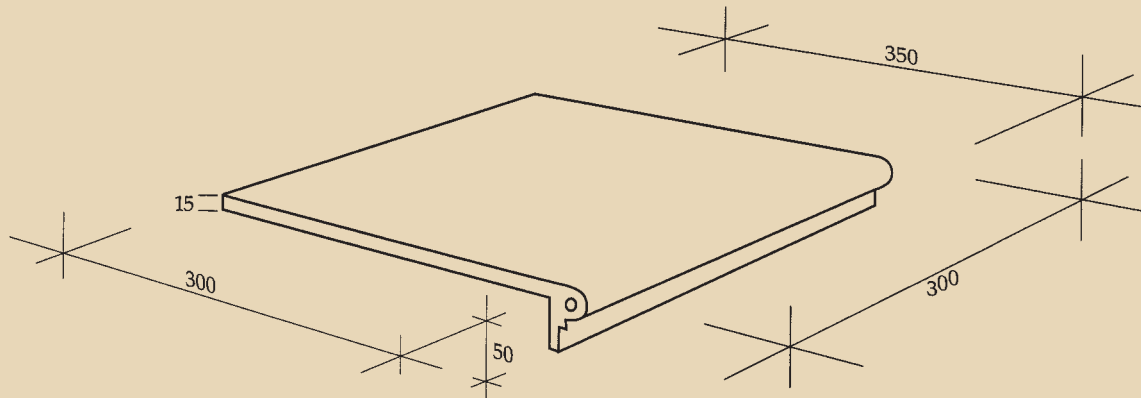

TECHNICAL DATA

<i>Cold Water Absorption</i>	Average 24 hours Cold Water Absorption	1.3% to 3.9%	
<i>Hot Water Absorption</i>	Average 2 hours Hot Water Absorption	3.0% to 5.2%	ISO 10545-2:1995
<i>Characteristic Expansion</i>	Average Accelerated Expansion	0.005% to 0.050%	ISO 10545-10:1995
	Characteristic Expansion	0.2 to 0.6 mm/m	
<i>DeepAbrasion</i>	Average Abraded Volume	114 to 166	ISO 10545-6:1995
<i>Modulus of Rupture</i>	Mean	17.93N/mm ²	ISO 10545-4:1994
<i>Breaking Strength</i>	Mean	2703N	ISO 10545-4:1994
<i>Slip Resistance</i>	Coefficient of Friction - mean 53 to 57 depending on colour selection. AS/NZS 4586:1999		
	Method of Test: Wet Pendulum. Classification. 'V' & High 'W'. Interpretation; Low risk.		
	Passes wet slip resistance requirement of AS/NZS 3661.1:1993.		
	Wet/Barefoot Ramp mean angle of inclination: 18° to 20° Class A & B AS/NZS 4586:1999		
<i>Salt Attack</i>	Pass: All Colours.		AS/NZS 4456.10.1997
<i>Frost Resistance</i>	Pass : All Colours		ISO 10545-12:1995

The data provided here is an indication only of the range of Barossa Ceramics Pty Ltd Terracotta products. The Company will provide, on request, full details of specification and product tests to allow the purchaser or their agent to satisfy themselves as to the suitability of the product for any particular purpose. The Company endeavours to continually improve products and as such reserves the right to change the above specification without notice.

